

SECTION B-B

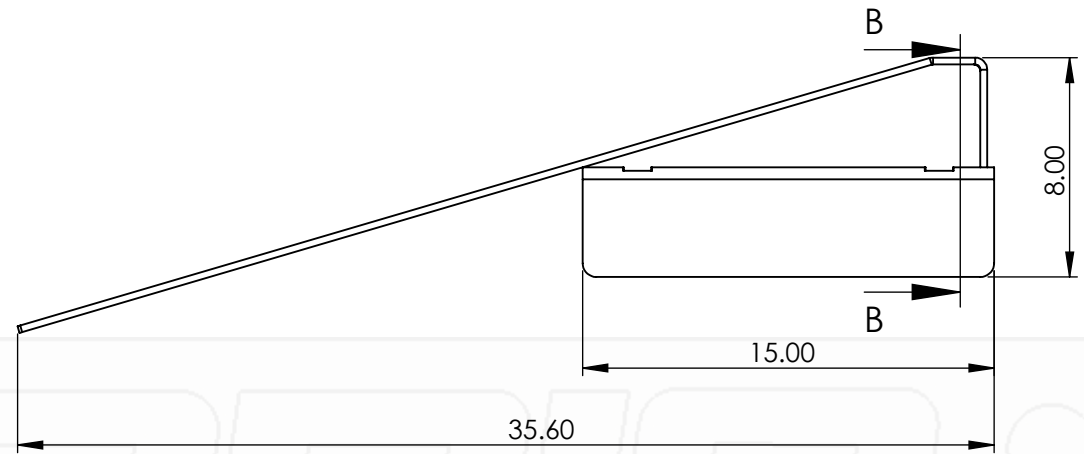

"ALL MATERIAL IS 1/4" THICK, AND IS BOX DESIGNED FOR STRENGTH".

TRIM EXCESS
HEAT AND BEND TO MATCH FRAME ANGLE

DRILL AND BOLT TO MATCH NEW OR
EXISTING HOLES IN FRAME
DRILL FOR (3) 1/2" BOLTS MINIMUM

****SOLD IN SETS: 1 LEFT SIDE & 1 RIGHT SIDE****

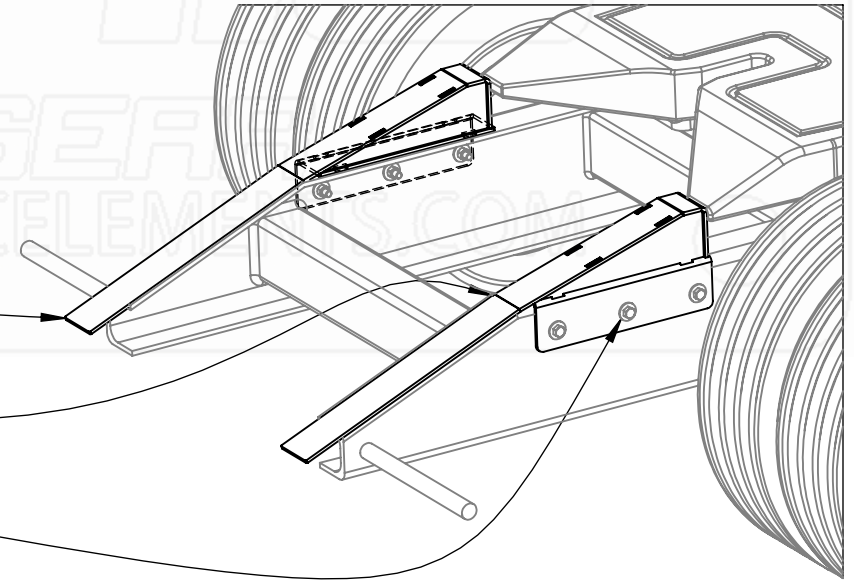

Part No.:

1955

MATERIAL: 1008 PO

Approx. Weight: 43.35 lbs

Surf. Area: 244.40 sq. ft.

THICKNESS: 0.250

ICONIC ELEMENTS (ICONIC METALGEAR) TITLE:

PROPRIETARY AND CONFIDENTIAL
NO PART OF THIS DOCUMENT MAY BE REPRODUCED, STORED IN A RETRIEVAL SYSTEM, OR TRANSMITTED
IN ANY FORM, WITHOUT THE WRITTEN PERMISSION OF Iconic Elements Inc. (ICONIC METALGEAR)

FINISH: HRAP

4" 5th Wheel Ramp

DWG. NO.: 1611-4-00-D-VC

REV: SHEET:

D 1 OF 2

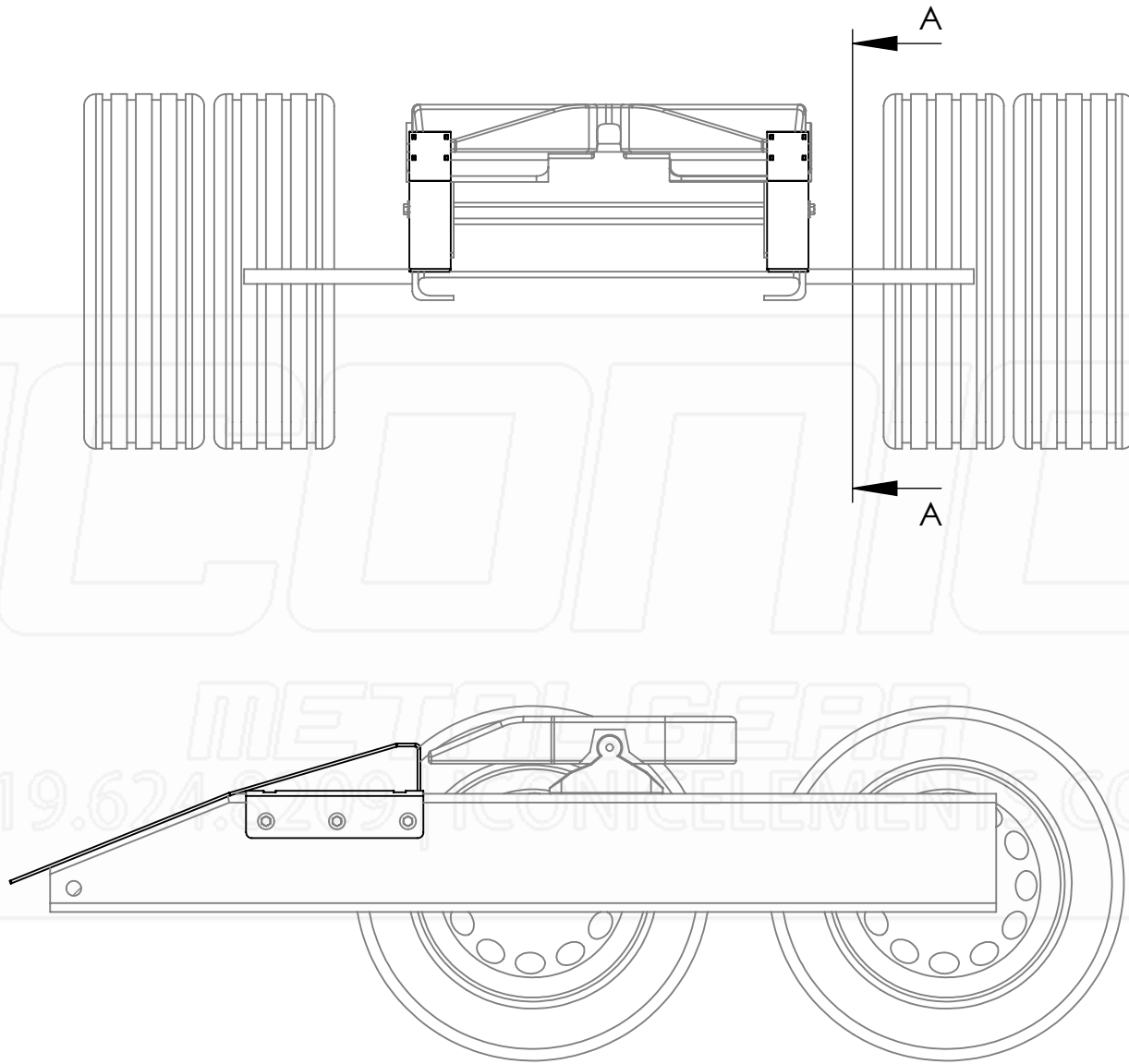

SECTION A-A

Part No.:	MATERIAL: 1008 PO	THICKNESS: 0.250	FINISH: HRAP	DWG. NO.: 1611-4-00-D-VC
1955	Approx. Weight: 43.35 lbs	ICONIC ELEMENTS (ICONIC METALGEAR) TITLE:		REV: SHEET:
	Surf. Area: 244.40 sq. ft.	<small>PROPRIETARY AND CONFIDENTIAL NO PART OF THIS DOCUMENT MAY BE REPRODUCED, STORED IN A RETRIEVAL SYSTEM, OR TRANSMITTED IN ANY FORM, WITHOUT THE WRITTEN PERMISSION OF Iconic Elements Inc. (ICONIC METALGEAR)</small>		D 2 OF 2
			4" 5th Wheel Ramp	

5

4

3

2

1

D

C

B

A