

SECTION B-B

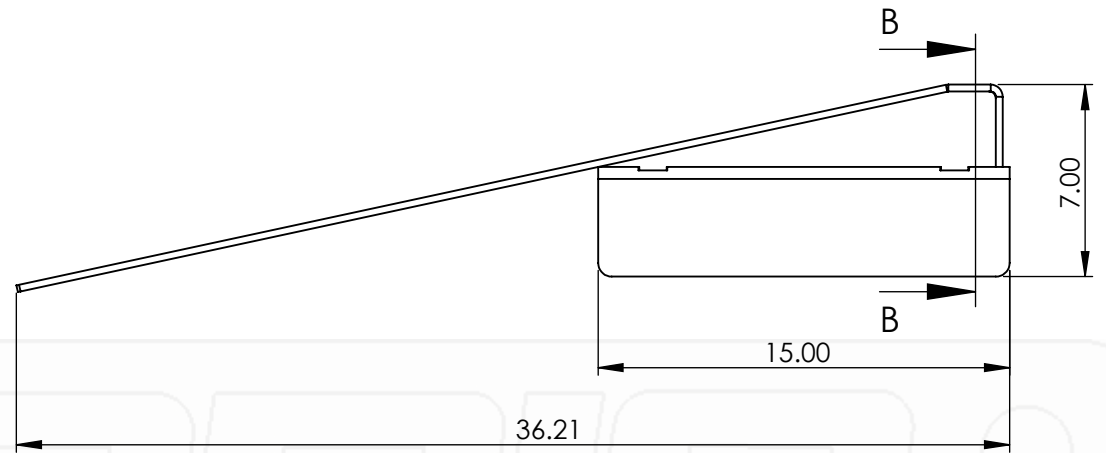

"ALL MATERIAL IS 1/4" THICK, AND IS BOX DESIGNED FOR STRENGTH".

- TRIM EXCESS
- HEAT AND BEND TO MATCH FRAME ANGLE
- DRILL AND BOLT TO MATCH NEW OR EXISTING HOLES IN FRAME
- DRILL FOR (3) 1/2" BOLTS MINIMUM

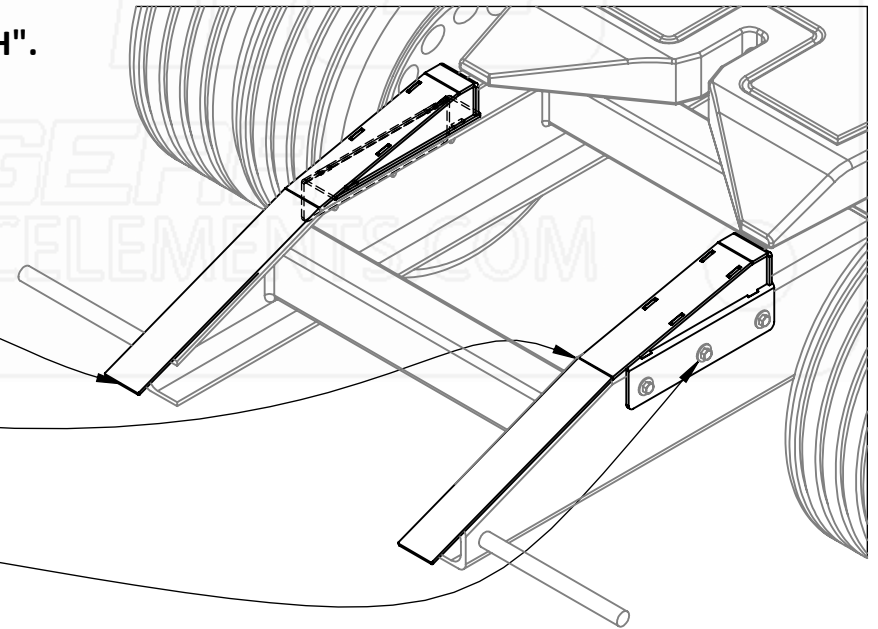

****SOLD IN SETS: 1 LEFT SIDE & 1 RIGHT SIDE****

Part No.:	MATERIAL: 1008 PO	THICKNESS: 0.250	FINISH: HRAP	DWG. NO.: 1611-3-00-E-VC
1954	Approx. Weight: 40.56 lbs	ICONIC ELEMENTS (ICONIC METALGEAR) TITLE:		REV: SHEET:
	Surf. Area: 243.84 sq. ft.	<small>PROPRIETARY AND CONFIDENTIAL NO PART OF THIS DOCUMENT MAY BE REPRODUCED, STORED IN A RETRIEVAL SYSTEM, OR TRANSMITTED IN ANY FORM, WITHOUT THE WRITTEN PERMISSION OF Iconic Elements Inc. (ICONIC METALGEAR)</small>		E 1 OF 2
3" 5th Wheel Ramp				

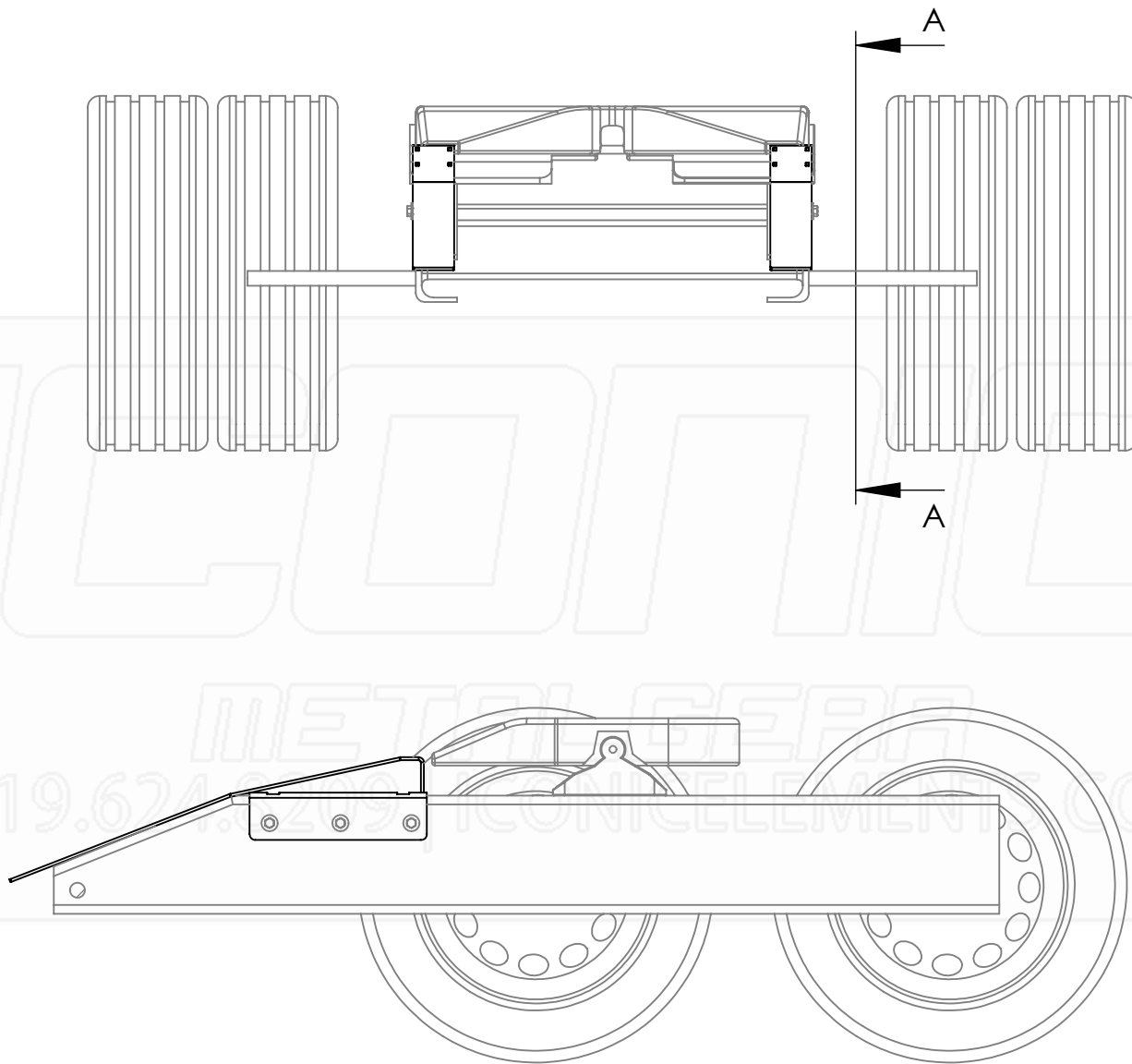

SECTION A-A

Part No.:	MATERIAL: 1008 PO	THICKNESS: 0.250	FINISH: HRAP	DWG. NO.: 1611-3-00-E-VC
1954	Approx. Weight: 40.56 lbs Surf. Area: 243.84 sq. ft.	ICONIC ELEMENTS (ICONIC METALGEAR) TITLE: <small>PROPRIETARY AND CONFIDENTIAL NO PART OF THIS DOCUMENT MAY BE REPRODUCED, STORED IN A RETRIEVAL SYSTEM, OR TRANSMITTED IN ANY FORM, WITHOUT THE WRITTEN PERMISSION OF Iconic Elements Inc. (ICONIC METALGEAR)</small>		REV: SHEET: E 2 OF 2
3" 5th Wheel Ramp				

5

4

3

2

1

D

C

B

A