

SECTION B-B

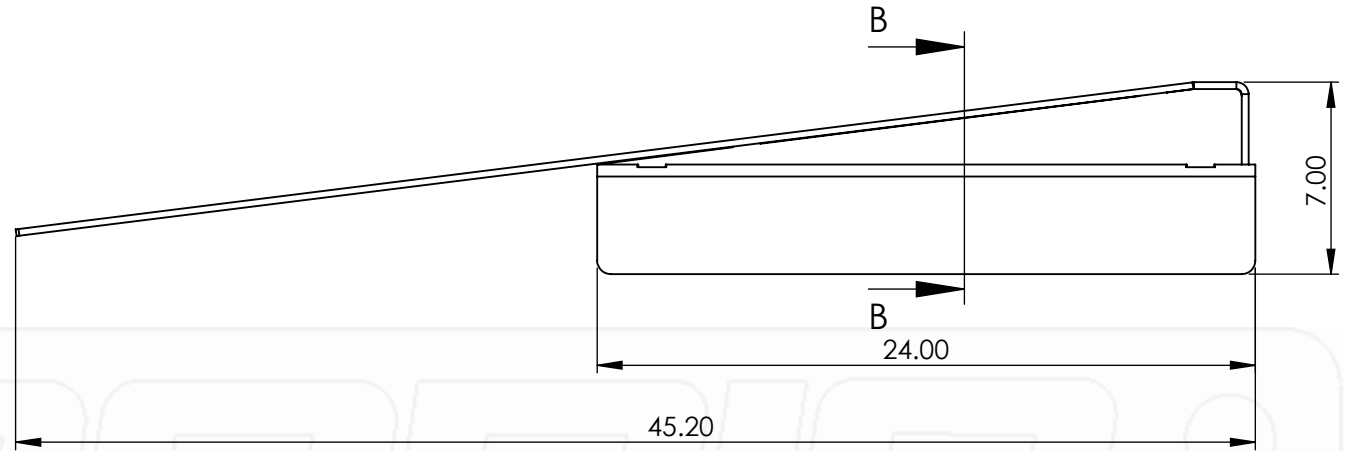

"ALL MATERIAL IS 1/4" THICK, AND IS BOX DESIGNED FOR STRENGTH".

TRIM EXCESS
HEAT AND BEND TO MATCH FRAME ANGLE

DRILL AND BOLT TO MATCH NEW OR EXISTING HOLES IN FRAME
DRILL FOR (3) 1/2" BOLTS MINIMUM

****SOLD IN SETS: 1 LEFT SIDE & 1 RIGHT SIDE****

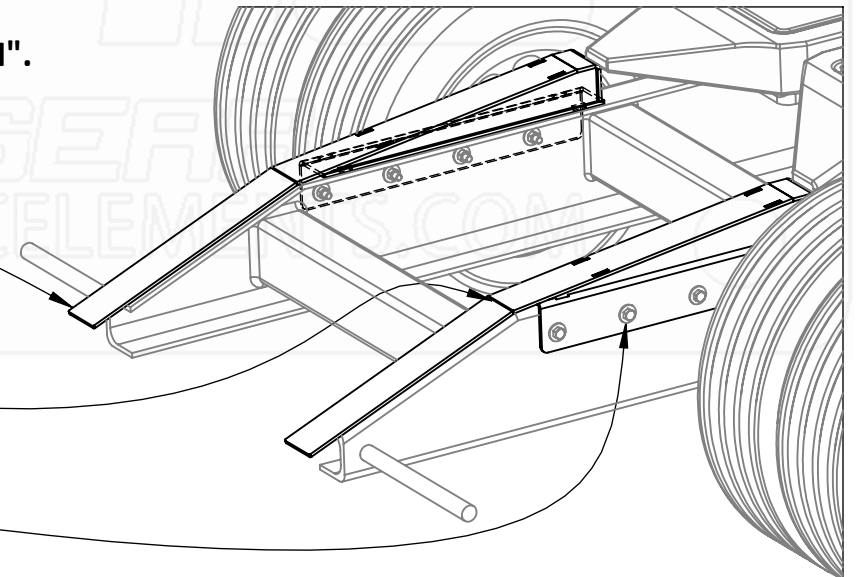

Part No.:

1950

MATERIAL: 1008 PO

Approx. Weight: 57.30 lbs

Surf. Area: 247.57 sq. ft.

THICKNESS: 0.250

ICONIC ELEMENTS (ICONIC METALGEAR) TITLE:

PROPRIETARY AND CONFIDENTIAL
 NO PART OF THIS DOCUMENT MAY BE REPRODUCED, STORED IN A RETRIEVAL SYSTEM, OR TRANSMITTED IN ANY FORM, WITHOUT THE WRITTEN PERMISSION OF Iconic Elements Inc. (ICONIC METALGEAR)

FINISH: HRAP

3" 5th Wheel Ramp

DWG. NO.: 0845-3-00-H-VC

REV: SHEET:

H 1 OF 2

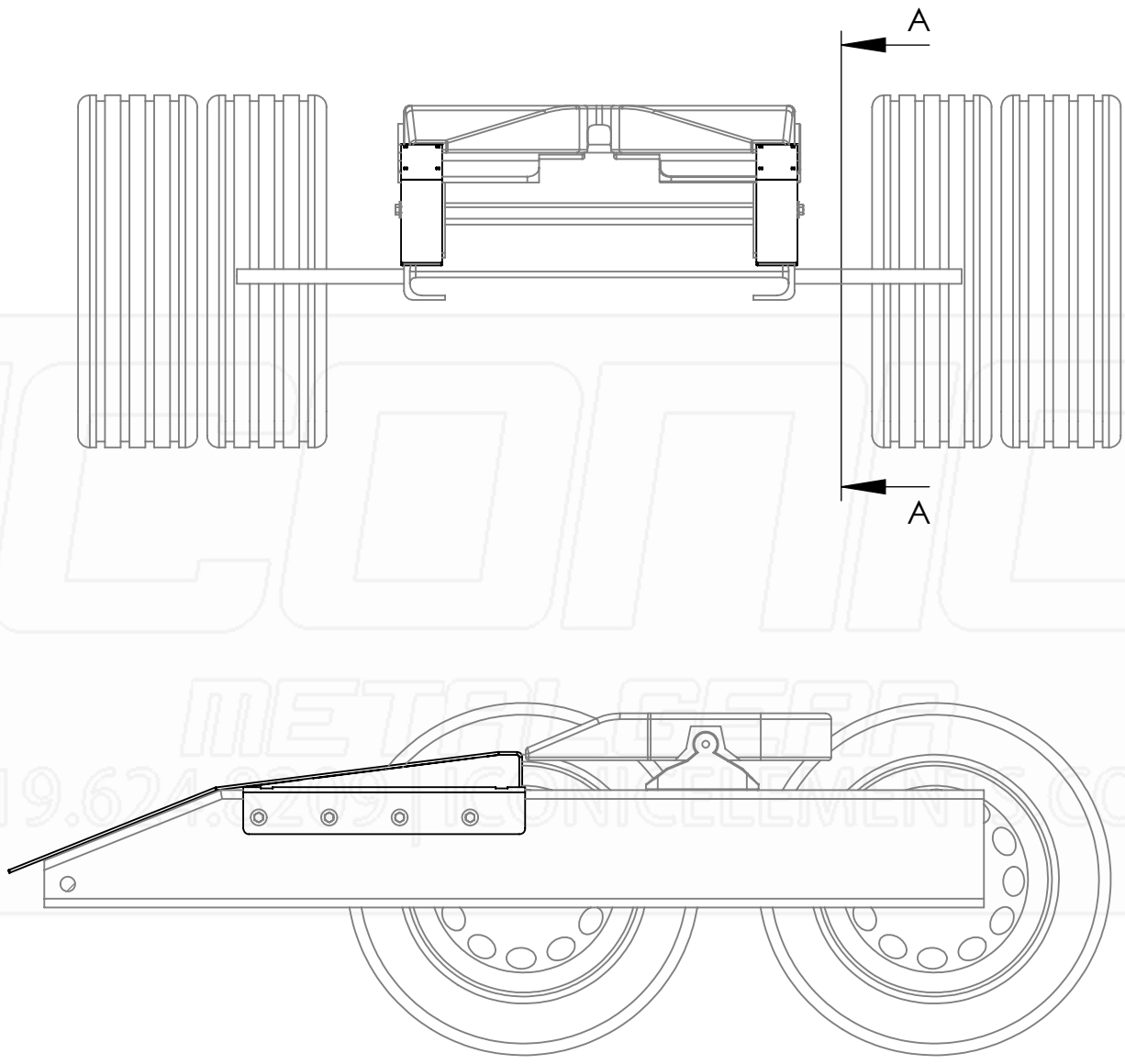

SECTION A-A

Part No.:	MATERIAL: 1008 PO	THICKNESS: 0.250	FINISH: HRAP	DWG. NO.: 0845-3-00-H-VC
1950	Approx. Weight: 57.30 lbs	ICONIC ELEMENTS (ICONIC METALGEAR) TITLE:		REV: SHEET:
	Surf. Area: 247.57 sq. ft.	<small>PROPRIETARY AND CONFIDENTIAL NO PART OF THIS DOCUMENT MAY BE REPRODUCED, STORED IN A RETRIEVAL SYSTEM, OR TRANSMITTED IN ANY FORM, WITHOUT THE WRITTEN PERMISSION OF Iconic Elements Inc. (ICONIC METALGEAR)</small>		H 2 OF 2
			3" 5th Wheel Ramp	